

# HSP 300

**Tam Otomatik Hızlı Kesim  
Testere Tezgahı**  
Full Automatic High Speed Cutting  
Bandsaw Machine

**Cuteral**  
INTEGRATED CUTTING SYSTEMS



**1** **PAKET KESİM**  
Bundle Cutting

**2** **OTOMATİK  
YÜKSEKLİK AYARI**  
Automatic Height  
Control

**3** **ŞERİT KOPMA  
SENSÖRÜ**  
Blade Breakage  
Sensor

**4** **KESME BASINÇ  
AYARI**  
Cutting Pressure

# Ölçüler / Dimensions

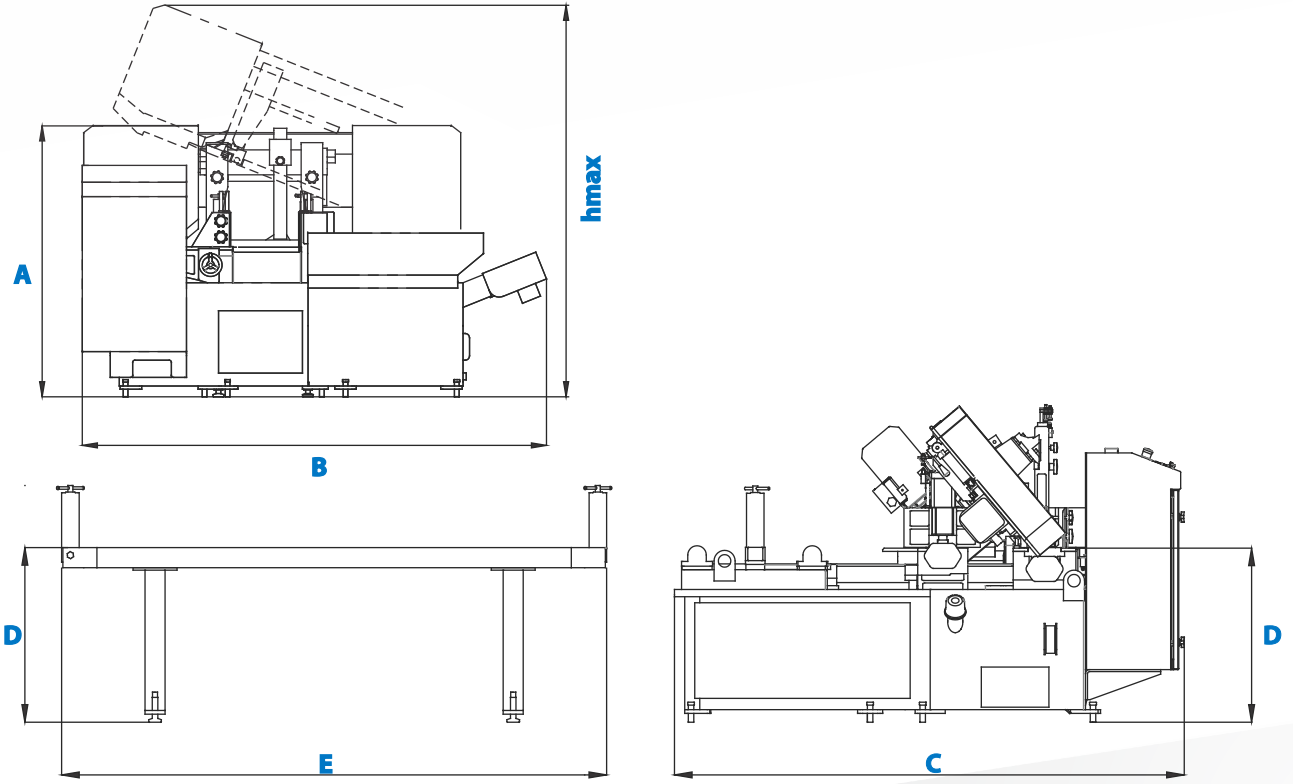

<b>A</b>	1258 mm 49.53 inch	<b>B</b>	2175 mm 85.63 inch	<b>C</b>	2050 mm 80.71 inch	<b>D</b>	670 mm 26.38 inch	<b>E</b>	2170 mm 85.43 inch	<b>hmax</b>	1835 mm 72.24 inch
----------	-----------------------	----------	-----------------------	----------	-----------------------	----------	----------------------	----------	-----------------------	-------------	-----------------------

Otomatik Automatic	Şerit Ölçüsü Blade Dimension 34 x 1,1 x 3820 mm 1.34x0.043x150.4 inch	Şerit Motoru Blade Motor 3 kW - 1400 d/dak 4 hp / 1400 rpm	Talaş Fırçası M. Chip Brush M. 0.09 kW -1500 d/dk 0.12hp / 1500 rpm
Hidrolik Motor Hydraulic Pump Motor 0.75 kW / 1400 d/dk 1 hp / 1400 rpm	Soğutucu Motor Cooling Liquid Motor 0.12kW 3000d/dk 0.16hp - 3000 rpm	Talaş Konveyörü Motoru Chip Conveyor Motor 0.18 kW / 1400 d/dk 0.24 hp / 1400 rpm	Maksimum Güç Maximum Power 4.14 kW 5.55 hp
Kesme Hızı Cutting Speed 15 m/dk- 49 ft/min 100 m/dk- 328 ft/min	Ağırlık Weight 1600 kg 3527 lbs	Voltaj Voltage 400 V 400 V	Malzeme Sıkma Sistemi Material Clamping System Hidrolik Hydraulic
			Şerit Germe Sistemi Blade Tensioning System Hidromekanik Hydramechanic

Kesim Kapasitesi Cutting Capacity 310 mm 12.2 inch	Kesim Kapasitesi Cutting Capacity 310 mm 12.2 inch	60°	45°	30°	0°	15°	45°	60°
Paket Kesim Kapasitesi Total Cutting Capacity 40 - 150 mm 1.57-5.90 inch	Paket Kesim Kapasitesi Total Cutting Capacity 145 - 230 mm 5.70-9.05 inch	60°	45°	30°	0°	15°	45°	60°



#### ŞERİT KOPMA SENSÖRÜ 1

Kasnağa yerleştirilen sensör yardımıyla şerit koptuğu durumlarda makinenin otomatik olarak durması sağlanır.

**BLADE BREAKAGE SENSOR**  
This sensor in the idle pulley stops the machine automatically when the blade is broken.



#### KESME BASINÇ AYARI 3

Malzemenin özelliğine göre testerenin kesme basıncı ayarlanabilir.

**CUTTING PRESSURE**  
Cutting pressure can be adjusted according to material's hardness.



#### PLC KONTROL 5

Tüm elektrik ve hidrolik fonksiyonlar PLC kontrol ünitesi ile sağlanır.

**PLC CONTROL**  
PLC control for all electrical and hydraulic functions



#### OTOMATİK YÜKSEKLİK AYARI 2

Testere kafasının malzemeye hızlı yaklaşmasını ve herhangi bir yükseklik ayarına gerek kalmadan kesme yüksekliğine otomatik kalkmasını sağlar.

**AUTOMATIC HEIGHT CONTROL**  
Automatic work height control by fast approach bar sensor

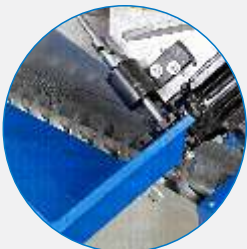

#### TALAŞ KONVEYÖRÜ 4

Kesim arasında oluşan talaşları otomatik uzaklaştırmaya yarar.

**CHIP CONVEYOR**  
Chip conveyor conveys accumulated chip to portable chip box



#### TALAŞ FIRÇASI 6

Motor tahrikli talaş fırçası yardımıyla şerit dişleri arasındaki talaşların temizliği sağlanır.

**CHIP BRUSH**  
Motorized chip brush cleans all chips in the blade teeth.





### MENGENE SİSTEMİ

7

Hareketli mengenerler, el yardımıyla kesilecek malzeme genişliğine göre kaydırılarak ayarlanabilir.

#### CLAMPING SYSTEM

Movable clamps can be adjusted manually according to material's diameter or width.



### DAYAMASIZ KESİM

8

Özel sayıcı vasıtasıyla kesilen malzemenin boyu hassas olarak ayarlanabilir.

#### ACCURATE CUTTING

Accurate length measuring by special counter



### HIZLI KESİM

9

Ön ve arka mengenerler üzerine kolaylıkla monte edilebilen hidrolik üst baskı ile paket kesim yapma imkânı.

#### BUNDLE CUTTING

Bundle cutting can be done by hydraulic bundle clamping, which is easily mountable on front and back clamps.



### ŞERİT GERDİRME

10

Hidrolik kumandalı şerit gerdirme sistemi ile kesim esnasında şeridin sürekli aynı gerginlikte olmasını sağlar.

#### BLADE TENSIONING

Hydraulic blade tensioning system makes it possible to put the blade tension at the same level during cutting.



### ÇİFT MENGENE

11

Besleme arabası üzerindeki her iki mengene de hidrolik olarak kumanda edilebilir.

#### SHUTTLE VISE

Shuttle vise on the feeding bar can be controlled hydraulically.



### KUMANDA PANELİ

12

Kullanıcıya kolaylık sağlayan ergonomik kontrol paneli.

#### CONTROL PANEL

Easy to use, ergonomic control panel.



### MALZEME BESLEME SİSTEMİ

13

Malzeme beslemesi hidrolik silindir yoluyla hassas olarak yapılır.

#### FEEDING SYSTEM

Accurate material feeding by hydraulic cylinder

